



FLx-LT-XP
CONVENTIONAL
CONTROL PANEL
FL2/4/8/12 LT-XP

**Installation,
Configuration
and Operating
Manual**

MAY 2008
MIE-MI-580I_FL rev.003

Information in this document is subject to change without

Index

Introduction	3
System design	3
CE Mark	3
General	3
Operation	4
Main Features	4
Keypad	6
System led indicators	7
Installation	10
Pre-installation check list	10
Cabling	11
Cabling	12
Installation and commissionning	13
Connecting call points	14
Connecting detectors	14
Sounder circuits	15
Alarm and fault relays connection	16
Board diagram	17
CONFIGURATION	18
DELAY 1	19
DELAY 2	19
Fault / Alarm by short circuit	20
Zone type	20
Sounder activation by zone	21
Disablement led indication with delay	21
Cancel delays with 2 zones in alarm	22
Special functions (do not comply with EN54)	23
Technical specifications	24

INTRODUCTION

System design

It is assumed that the system, of which this control panel is a part, has been designed by a competent fire alarm system designer in accordance with the requirements of EN54 Part 14 (23007/14) and any other local codes of practice that are applicable. The design drawings should clearly show the positions of the field devices and the control equipment.

FLx-LT-XP control panels are manufactured meeting national and local standards. The control panel complies with the requirements of EN54 Parts 2 and 4

However, some installation and configuration practices may contravene the requirements of EN54. Where there is a possibility of such an occurrence, a suitable warning is given with brief details of the EN54 requirement. Refer to proper authorities to confirm the requirements.

CE Mark

This panel is CE Marked to show that it conforms to the requirements of the following European Community Directives:

- Electromagnetic Compatibility Directive 89/336/EEC (and the amending Directives 92/31/EEC, 93/68/EEC).
- Low Voltage Directive 73/23/EEC (and the amending Directive 93/68/EEC).

General

FLx-LT-XP control panels are factory-configured as 2, 4, 8 or 12 zones.

The control panel can support an unlimited number of manual call points and a limited number of detectors by zone, according to the limits of the design and installation standards that are applicable.

The panel is self-contained with integral power supply and space provision for two sealed, lead-acid standby batteries and complies with the requirements of EN54 Parts 2 and 4.

The panel functions are microprocessor controlled and there are some programming options in addition to those required by applicable standards. Moreover, sounder delays, zone monitoring or test mode are also available. Check the default configuration before making any test.

Note:

While every effort is made to ensure the accuracy of the content of this manual, the manufacturer reserves the right to change the information without notice.

OPERATION

Main Features

FLx-LT-XP control panels have been designed to be easy to use and program and with the best quality and performance, providing users with an efficient and safe product which meets the current applicable standards.

System

The system is controlled by a processor with a software that monitors and ensures system's security, which increases its reliability.

System access is restricted by password or keyswitch (level 2).

Front indicator leds and buzzer show the current state of the system.

The panel has 10 system status leds indicators, zone led indicators (alarm, fault/disable/test), zone push buttons (disable/test/enable zone) and 5 function push buttons.

Mains Supply

FLx-LT-XP control panels is supplied with a change over power supply, with battery charger, of 45W (1.6A) for FL2/4-LT-XP and of 65W (2.4A) for FL8/12-LT-XP to provide power for both mains supply (220Vca) and/or batteries.

Power supply is monitored permanently by the CPU microprocessor. Mains supply fault is delayed 8 minutes to avoid warnings due to momentary power shutdowns.

Alarm zones

FLx-LT-XP control panels have 2, 4, 8 and 12 detection zones. Up to 32 sensors (ECO1000 series) may be connected to each zone.

The control panel differentiates between an alarm from a sensor and from a call point.

The operation of a zone can be configured as:

-Normal zone: Immediate activation of alarms.

-Confirmed delay zone: the alarm must keep activated for 30 sec. It does not apply to detectors.

-Verified zone: The zone is reset in the first alarm and keeps monitoring for 10 min. If a new alarm is generated within the verification time (10 minutes), the alarm is confirmed and activates the system. Otherwise, the process is reset without indicating any alarm.

A short circuit in any zone may be configured to be detected as an alarm or fault (EN54/2).

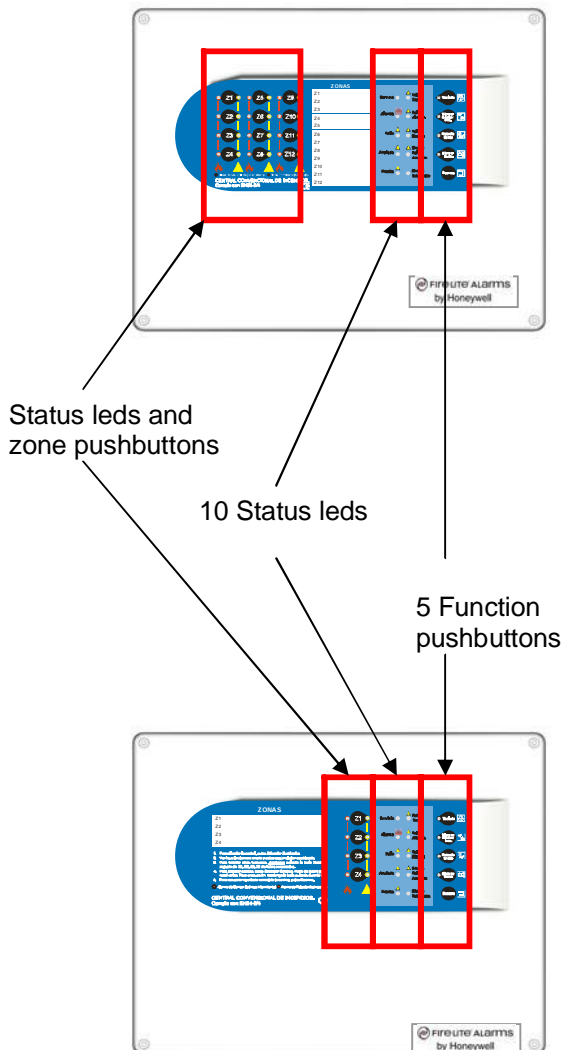

EN-54 ?

EN54-2: Appendix D
No more than 32 alarm devices
may be connected to a zone

EN54-2: 8.2.4
A short circuit or power cut must
be indicated as a zone fault

Outputs

A FLx-LT-XP LT control panel has:

- 2 sounder outputs which can be configured to be activated by specific zones. Any zone alarm will activate all sounders, by default.
- 1 alarm relay which is activated when an alarm is confirmed immediately and is latched together with the general alarm led; and 1 fault relay which changes its state after any fault in the system or lack of power supply.

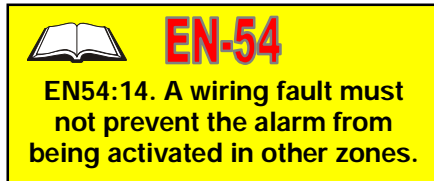

Sounder delay

The user can start or stop the delays configured for sounders by pressing the key  (Delay on/off).

From Access level 3 (programmer), 2 different delay times can be configured (10 minutes max.)

- Time 1 (Acknowledge): During this time, user must press the key  (Buzzer Mute) to acknowledge the alarm; otherwise, sounders will activate. Configurable times: 0, 30, 60, 90, 120, 150, 180, 210, 240 and 300 sec.
- Time 2 (Inspection): Additional time for considering the alarm. After this period of time, sounders will activate. Configurable times: 0, 1, 2, 3, 4, 5, 6, 7, 8, 9 and 10 min.

Delay operation

Alarm in a delayed zone

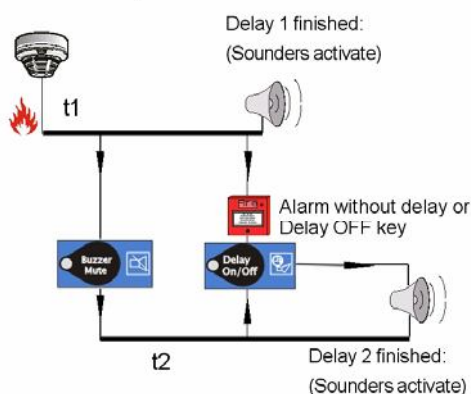

The activation mode of sounders can be configured by zone, with or without delay for manual call points or detectors. Sounders may also not be activated by a specific zone.

Moreover, 2 zones in alarm at the same time can also disable the operating delays.

Users can stop the operating delays from the Access level

1 by pressing  (Delay on/off).

When a manual call point is activated, the operating delays will be cancelled.

Auxiliary 24V output

The control panel has a 24V power supply for the connection of external low consumption devices (315mA FL2/4-LT-XP and 600mA FL8/12-LT-XP). This output can be configured as resettable or non-resettable. Power supply is interrupted when the system is reset.

Configuration

The system can be configured from Access level 3 (programmer) to be adapted to the different requirements of installations.

The system configuration must be carried out by qualified people.

Keypad

FLx-LT-XP control panels have 5 function push buttons and a push button for each zone.

The access to functions and push buttons is limited to 2 access levels for users and a third access level only for programmers.

Functions available in Access level 1 (user)

In Access level 1, the user can only visualize the system status and silence the buzzer:



KEYPAD: Press this key for 3 seconds to make a led test: all the leds and buzzer will activate for a few seconds.



BUZZER MUTE: Press this key to silence the buzzer. If Buzzer mute key is pressed while Time 1 delay (acknowledgement) is activated, Time 2 delay (Inspection) will start. Press **Delay On/off** key to stop delays from Access Level 2.

Any function which requires Access level 2 is indicated by a “beep” and a flash from Keypad key.

Access level 2 (User)

All functions available in access level 1 are also available in access level 2.

Access level 2 (Enable keypad)

In order to have access to user functions (level 2) and enable the keypad, press Keypad key while entering the access code 1221 at the same time, by pressing the zone keys Z1, Z2, Z2 and Z1 in this order. Keypad push button led will be illuminated to indicate the access level 2. If no other push button is pressed in 3 minutes, the control panel will return to access level 1.



DELAY ON/OFF: If there are delays configured for sounders, the Sounders delayed led will light. Press the Delay On/Off key, then the Delay On/off led will be illuminated with the delays disabled. While delays are operating, press the Delay On/Off key in order to disable the delays and activate the sounders immediately.

This key allows the user to stop operating delays.



SOUNDERS STOP (Evacuation 3s.):

-Silence and activate sounders: Press the Sounders Stop key to silence the sounders, then the Sounders Stop led will be lit. Press this key again to activate sounders again.

-Disable sounders: When no alarms are activated, press the Sounders Stop key once to disable sounders, then the Disablement and Sounders fault/disabled leds will be lit. Press the Sounders stop key again to activate the sounders. The disabled sounders will not be activated in case of alarm.

-Evacuation: Press the Sounders Stop key for 3 seconds to activate all sounders.



RESET: Press this key to reset the system. Any current alarm or fault will be indicated again after resetting the system.

NOTE: Check the alarm or fault cause before resetting the system.

BUZZER



FLx-LT-XP control panel has an inner buzzer to warn about events:

-Buzzer steady: Alarm registered in a zone or Evacuation activated.

-Buzzer flashing: System fault. 220Vac fault is delayed 10min.

Press Buzzer Mute key from Access level 1 or 2 in order to silence the buzzer.

ZONES KEYS:

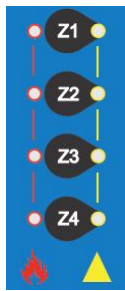

- To disable a zone, press the zone key once. The Disablement and Zone key leds will be lit.

If a zone is already disabled, no alarms or faults will be received from this zone.

If a zone with an event is disabled, this zone will be disabled for new events but the current alarm or faults will only disappear after a system reset.

- To test a zone, press a zone key from the previous disablement status. The Test and Zone key leds will flash to indicate the test status.

The alarms in zones being tested will activate all the sounders for a few seconds and the zone is reset automatically.

While zones are tested, the fault relay changes its status to indicate the new condition.

The alarm of any zone in normal status, not under test, will disable the test mode and activate the system normal operation.

System led indicators

FLx-LT-XP control panel has 10 system indicator leds and 2 more leds for each zone.

System led indicators

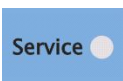

Service (green): This led is lit in green to indicate that the system is under normal operation.

- Led off: If the Power led is off, the system will not operate. Check the mains power supply and battery and their fuses.



Alarm (red): This led is lit when any zone is in alarm condition.

- Led on: The Fire led illuminates in red to indicate that there is a fire alarm in any zone. Check the zone leds to identify what zone the alarm is in. Inspect the affected zone to identify the cause of the alarm. Press the Reset key (access level 2) to make the system return to its normal status.

In case of Evacuation, only the alarm led is on (zone leds off).



Fault (yellow): The fault led is lit when there is a fault in the system or zones.

- Led on: The fault led illuminates in yellow to indicate that there is a fault in the system. Check the System led indicators that are on and the zone leds or Sounder fault/disabled led flashing quickly in order to identify the fault. Mend the fault and press the Reset key (access level 2) to make the system return to its normal status.



Disablement (yellow): This led indicates that any zone or sounder output circuits are disabled.

If there are sounders delays, the Disablement led will be lit together with the Sounders delayed led (EN54/2). From the access level 3 (programmer), it is possible to programme that the sounder delays do not light the Disablement led.

- Led on: This led indicates that there are zones or sounders disabled or delayed. In order to disable delays temporarily, press the Delay On/Off key from access level 2 (The led of the appropriate key will be lit). Check that the yellow Zone and the Sounder fault/disabled leds illuminate in steady mode. Enable the disabled zones or sounders by pressing the corresponding zone key or the SOUNDERS STOP key (Disablement led will be turned off). If required, enable the delays again.

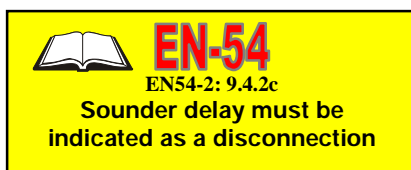



Test (yellow): This led indicates that a zone is under test.

-Led on (flashing slowly in access level 2): This indicates that a zone is under test. Check the Zone leds illuminated (flashing slowly with Test led in access level 2). Press the relevant zone key (access level 2) in order to restore its normal status.



Earth fault (yellow): This led indicates that an earth leakage has been detected in zone or sounder circuits, digital input or Aux. 24V.

-Led on: System earth leakage. Please contact the installing company. Earth leakages imply a high risk for the system. Once the earth leakage condition has disappeared, press Reset (access level 2) to make the system return to its normal status.

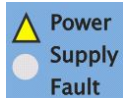

Power Supply fault (yellow): This led indicates that there is a fault in the control panel power supply.

-Led on: Power supply fault. Check the 220 Vac mains power supply and batteries, the fuses of both and the Aux 24V output. Switch off the +-24 V terminals if necessary. When the fault cause has been cleared, press the Reset key (access level 2) to make the system return to its normal state.

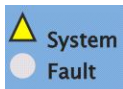

System fault (yellow): A serious system fault has been detected.

-Led on: System fault. Switch off the 220V power supply and batteries until the Power led is off and connect the power supply again. If the fault continues, contact your supplier.



Sounder fault/disabled (yellow): There is a fault in the sounder circuits or sounders are disabled.

-Led flashing quickly: This indicates that there is a fault in the sounder circuit due to a short circuit, open circuit or overload. Check the circuits and the end of line resistance; check also the sounder fuses. Once the fault cause has been cleared, press the Reset key (access level 2) to make the system return to its normal status.

-Led on (and disablement led also on): Sounders are disabled. Enable the sounders by pressing the Sounders Stop key (access level 2) until the zone yellow led is off.



Sounders delayed (yellow): This led indicates that sounders are programmed with delays for detector alarms in a zone.

-Led on: There are delays configured for sounders.

-Led flashing: Delays operating. When delays are finished, sounders are activated. Press the Delay On/off key to stop the operating delays. Sounders are activated immediately when there is an alarm in the system.

Zone leds



Zone fault/disabled/test (yellow): The relevant zone is in fault, test or disabled.

-Led flashing quickly (and fault led also on): The zone is in fault condition. Check the zone wiring. Once the fault cause has been cleared, press the Reset key (access level 2) to make the system return to its normal status.

-Led on (and disablement led also on): The zone is disabled. Enable the zone by pressing the zone key (access level 2) until the zone yellow led is off.

-Led on (and test led also on) / (flashing slowly with test led on in access level 2): The relevant zone is being tested. Press the Zone key (access level 2) until the zone yellow led is off.



Zone alarm (red): This led indicates that there is a device under alarm condition in this zone.

-Led flashing: This indicates that there is a detector in alarm.

-Led on: This indicates that there is a call point in alarm.

Check the alarm cause and press the Reset key (access level 2) to make the system return to its normal status.

INSTALLATION

Pre-installation check list

Before installing your control panel or fitting detectors, you must first ensure that the following criteria have been met. Failure to do this may not only result in damage to the equipment, but may also cause problems when commissioning the equipment or adversely affect its performance.

After removing the control panel from its packaging, and before you proceed with installing in its chosen location, check for any damage that may have been caused during transit. In the unlikely event that the panel has been damaged in transit, you **MUST NOT** install it but contact your supplier for their returns procedure.

Before selecting a location for the FLx-LT-XP control panel, **DO** make sure that:

- a. The ambient temperature is in the range: **+5°C to 35°C**
- b. The relative humidity is between: **5% and 95% (non-condensing)**
- c. The panel is wall mounted in a position which allows clear visibility of displays and easy access to operating controls. The height above floor level should be chosen such that the middle of the panel is just above normal eye level (approximately 1.5 metres)
- d. **DO NOT** locate the panel where it is exposed to high levels of moisture.
- e. **DO NOT** locate the panel where there are high levels of vibration or shock.
- f. **DO NOT** site the panel where there would be restricted access to the internal equipment and cabling/wiring connections.

Transient Protection

This equipment contains transient-protection devices. Although no system is completely immune from lightning transients and interference, for these devices to function correctly, and to reduce susceptibility, this equipment must be earthed correctly.

As with all solid state devices, this system may operate erratically or can be damaged if subjected to lightning-induced transients.

The use of outside aerial wiring is not recommended due to the increased susceptibility to nearby lightning strikes.

Batteries replacement

Batteries have a limited life. Mark the installation date of batteries in order to know their life span.

In case of replacement, use only batteries recommended by manufacturer and old batteries should always be disposed of in accordance with local regulations. Refer to Specifications Section in this manual for more information.

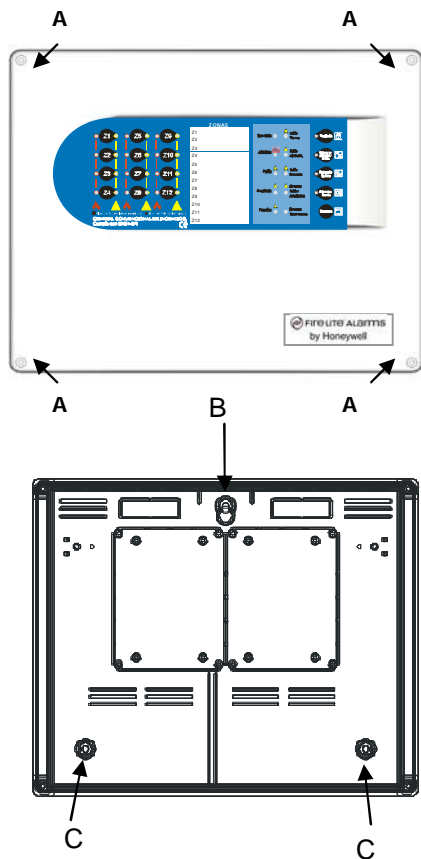

Assembly

Removing the cover

Remove the four front cover screws (A). Store the cover and screws safely until required for re-fitting.

Preparing cable holes

When a suitable location has been found for installing the control panel, prepare holes required for cable access. Open the required knockouts by means of a slot-ended screwdriver inclined towards you. While in this position, use something suitable to strike the top of the screwdriver to achieve a clean break of the knockout. To open knockouts, the box should rest on a suitable surface, like a working table to avoid being bent.

If you need to drill any new holes in the box, boards and power supply should be removed first and be kept safely to be refitted later.

Remove any debris with a brush before refitting the boards.

Back box fixing

The back box must be fixed to the wall with the screws at three fixing locations (see drawing) following the procedure described below (refer to Specifications Section for more information about back box dimensions).

Use 5 mm screws and appropriate studs.

Hold the back box assembly in the required position against the wall and mark the position of the keyhole (B).

Drill a hole and fit a 5 mm screw.

With the panel supported by the top screw, and ensuring that it is level, mark the other two screw positions (C).

Remove the back box and store safely. **Do not use the back box as a template while drilling holes.**

Drill holes and plug.

Screw the panel back box to the wall using three fixing holes and 5 mm screws.

Connect the wiring into the back box using cable glands and the

Cabling

All wiring should comply with current IEE wiring regulations or the applicable local wiring regulations. Note also the requirements of EN54-14 (23007/14) for cabling and interconnection of a fire detection and alarm system and the relevant parts of the low voltage regulation (REBT)

EMC Requirements: To meet the EMC requirements of the European Directives, it is necessary to ensure that a screened or metal sheathed cable is used.

As a general rule, **1.5 mm² cables is recommended.**

Cables should be brought into the back box through the 20mm knockouts provided on the top or the rear part.

Mains supply

The supply to the panel must be provided with a suitable and readily-accessible, double-pole, mains-disconnect device. **The mains supply must be suitably fused and rated according to the specifications.**

Always ensure that the mains cables are brought into the back box separately to the low-voltage wiring.

All the low-voltage cables should have a minimum 300Vac rating.

The termination of earth mains wiring must be done before the termination of any external cable screens.



Cable screen wires

Cables should be screened. Screen wires should be terminated inside the back box as follows:

- Screen tails should be of sufficient length to connect to the earth post at the commissioning stage. Once all screen wires have been terminated at the earth post, use the M4 nut, spring washer and two plain washers either side of the screen wires to make sure a good earthing bond is created.
- Use insulation sleeving on the tails between the cable entry position and the earth post. Run the tails close to the rear wall of the back box.

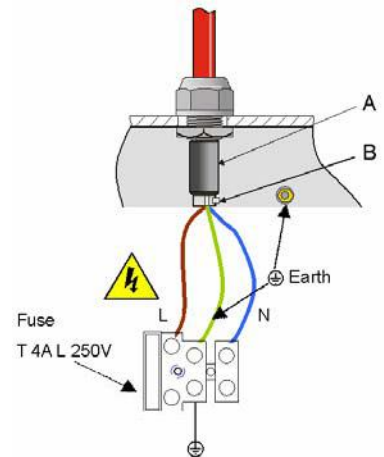

Cable for notification appliance circuits

There are a number of local restrictions for notification appliance circuits: notification and evacuation management cables and any other cable which require to be operating more than 1 minute after fire and cables which are installed in high risk areas must be fire-resistant for 30 minutes according to UNE-23.007-14. Moreover, current regulations must be considered for special risk areas.

Installation and commissioning

Backup batteries

A fire alarm control panel must be provided with backup power supply according to EN54-14.

The panel back box can hold up to two 12V, 7Ah lead acid batteries. Batteries are not supplied with the panel. The panel can function satisfactorily on batteries only, if required, when mains power is not available. However, this should only be done for short periods to avoid inadvertent discharge of the batteries.

Install the batteries in the back box. The batteries should be positioned so that their terminals are close enough to allow connection of the short interlink cable.

Connect the batteries according to the following drawing:

- Red battery lead (1)
- Black battery lead (2)
- Short battery interlink lead (3).

**CAUTION -
ENERGY HAZARD!
NEVER short the battery
terminals**

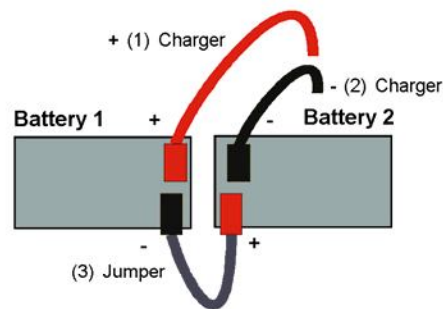
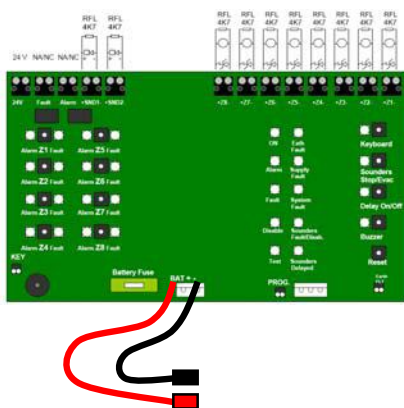

Zone wiring

Detector and call point wiring must be separated from other conduits with different voltage or usage.

FLx-LT-XP control panel has two, four, eight or twelve alarm zones (FL2/4/8/12-LT-XP)

Detectors and Call Points can be connected to the same zone wire, and the system identifies through the zone led if the alarm comes from **detectors (flashing led)** or **call points (steady led)**. Moreover, call point alarm may clear programmed delays, in compliance with EN54/2.

However, when installing detectors and call points in the same zone line, please, make sure other local regulations are followed. FLx-LT-XP control panels support an unlimited number of call points per line but some local regulations may limit this number. Please, check the current and applicable regulations before installing alarm devices.

End of Line Resistor

Zone lines must be terminated with the supplied **4K7 (4700Ω)** EOL resistor at the last device. This EOL resistor makes the zone stable to 24V (normal/quiescent status).

The EOL resistor must be installed in each zone.

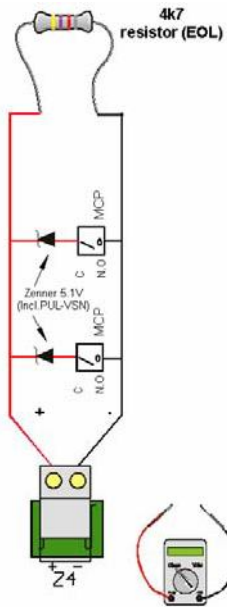

Connecting call points

Alarm call points are connected to the zone line by means of a 5.1V/0.25w Zener Diode (not supplied). PUL-VSN call points include this Zener Diode.

FLx-LT-XP control panels can support an unlimited number of call points in each zone but, according to EN54-14, no more than 32 fire detectors and/or MCPs may be connected to one zone.

Each call point must be series connected with a 5.1V (1/4W min.) Zener Diode between positive and negative (refer to the drawing on the left). This Zener Diode is included in PUL-VSN call point.

Before connecting the cable to the zone, use a meter to check that, between positive and negative, the value for the zone wiring must fit the EOL resistor value (4K7 Ohms).

Connecting detectors

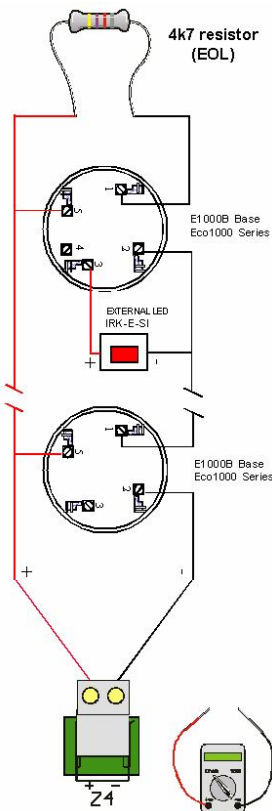

Fire detectors are connected directly to the zone line and are powered by this circuit.

A detector removal from the zone line must be indicated as a fault (EN45/2). For this reason, an EOL resistor must be installed in the output connection of the last detector, between zone positive and negative poles.

32 detectors can be connected to each line of a FLx-LT-XP control panel; however there may be local regulations more restrictive as for the quantity of detectors.

Please read carefully the detector's manuals before connecting them. Refer to the Technical specifications section of this manual to know what number of detectors are supported by zone.

According to EN54-2, the highest number of detectors supported by a zone is 32. Moreover, the detectors consumption must not exceed 3mA (3000 µA) with an EOL installed.

$$\text{Max. detectors number} < \frac{3000 \mu\text{A}}{\text{each detector consumption (} \mu\text{A)}} = \text{detector n.}$$

Example. Max. number of detectors by zone, using Eco1000 detectors.
Max. consumption: 80µA in standby.

$$\text{Max. detectors number} < \frac{3000 \mu\text{A}}{80 \mu\text{A}} = 37$$

Max. detectors = 37. However, as there cannot be more than 32 detectors in a zone, in this case, **the max. number of ECO1000 detectors connected will be 32.**

Before connecting the cable to the zone, use a meter to check that, between positive and negative, the value for the zone wiring must fit the EOL resistor value (4K7 Ohms).



EN54-2: Appendix D
No more than 32 alarm devices may be connected to a zone

Sounder circuits

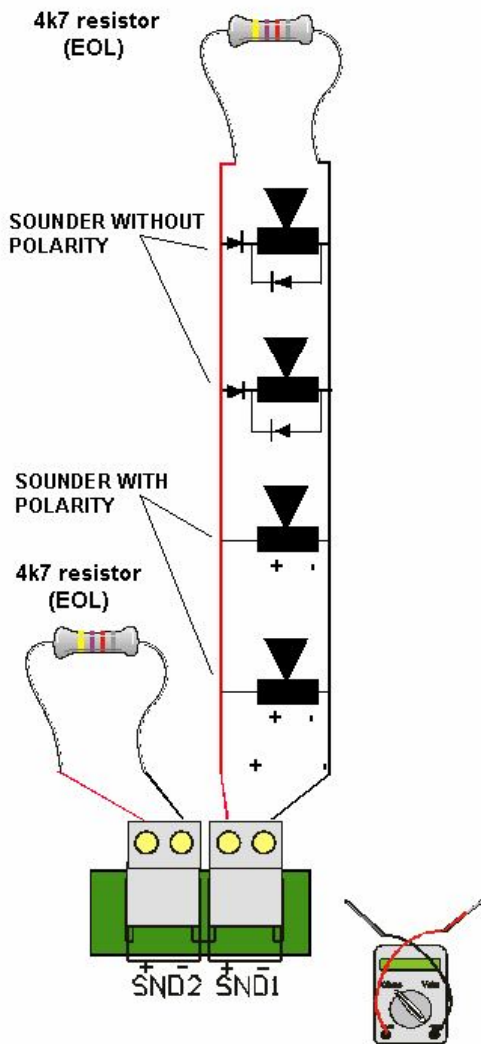

 **EN-54**
EN54:14
At least, 2 sounders must be installed in a building

Two sounder output circuits are provided.

Sounder circuit wiring must be separated from other cables.

There are some local requirements for Notification Appliance Circuits. Sounder circuits require to be activated for more than 1 minute after fire and must be fire resistant for, at least, 30 minutes, according to UNE-23.007-14.

Alarm sounders are connected directly to sounder's line. A fault in the sounders wiring must be detected (EN54/2) by installing an EOL resistor in the last sounder of the line between positive and negative poles.

Both sounder output circuits should have an EOL resistor even if it is not used.

The system reverts polarity of output in standby (-11V with EOL resistor fitted) due to sounders consumption in standby.

Each sounder circuit supports a maximum of **250mA when activated**, being protected against short circuits or overload. Check the device loads in order not to exceed the maximum allowed. Refer to Specifications section.

Connect the circuit to the panel output while observing correct polarity. If there are any reversed devices, the panel will indicate a fault.

Connect sounders only after finishing all connections to avoid false alarms.

When the output circuits have been connected, they may be tested by using the Sounders Stop/Evacuation push-button for 3 seconds, from Level 2 (entering the password **1221** or turning the keyswitch to the right). Sounders will turn on. Press the push-button again to silence sounders.

Before connecting the sounders, with the meter connected in reverse polarity (+ve to -ve and -ve to +ve) the reading should be 4k7.

Any fire in any zone activates sounders by default, but sounders may be configured to be activated by zone or with delays. Refer to Configuration section in this manual.

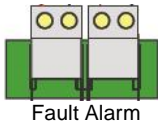

Alarm and fault relays connection

FLx-LT-XP control panel has two voltage free relays (NC or NO): fault relay and alarm relay.

Alarm relay is activated when an alarm is generated at the control panel (the Alarm led also turns on). Once activated, it is necessary to reset the control panel in order to reset the alarm relay and revert it to its normal status

The system allows to be configured so that the alarms are verified during a period of time. If an alarm is not confirmed, the alarm relay will not be activated. Refer to the operating and zone configuration sections of this manual

NC/NO relay configuration

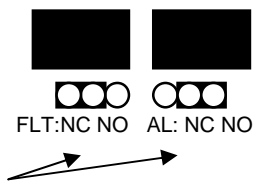

Jumpers to configure fault and alarm relays as NC or NO

Note: The drawing above shows the jumper position for fault and alarm NO contact in quiescent status.

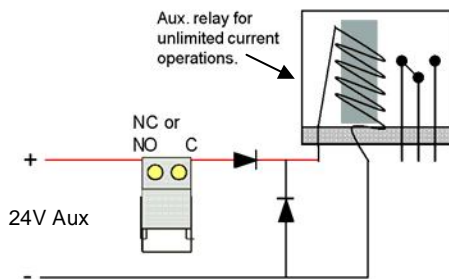

Each relay can be configured as NO or NC. Connect the FLT jumper and/or AL jumper as required, according to the drawing on the left

The fault relay is activated in standby and becomes deactivated when a fault is generated at the control panel or the panel power supply is cut.

Faults may be configured as latched or resettable. By default, faults are latched and it is necessary to reset the control panel so that the fault relay comes back to its normal (standby) status. On the other hand, resettable faults automatically revert the fault relay to its normal (standby) status, in case the fault is cleared

Each relay supports 1 A max. For high current or 240Vac, use external double relays with a polarization diode and a protective diode to avoid return spikes from coils. Refer to the drawing on the left.

Aux. 24 V outputs (resettable and non-resettable)

FLx-LT-XP has a 24Vcc output supplied from the control panel power supply and it is configurable, by means of the jumper located under 24V cont. switch, as resettable or non-resettable.

To select *non-resettable* voltage, connect the jumper 24Vcont to supply permanent 24 V.

To select *resettable* voltage, remove the jumper 24Vcont to supply resettable voltage. Power will drop to 0V for a few seconds each time the control panel is reset. This output is used to supply external external devices which need to cut the power to be reset.

Max. power is 300mA(FL2/4-LT-XP) and 600mA(FL8/12-LT-XP) at 24Vcc, electronically protected against short circuit or overload.

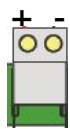

Jumper to configure the 24 V output as resettable or non-resettable

Note: The drawing above shows the jumper position for fault and alarm NO contact in quiescent status.

Warning! Whenever coils or relays are connected, protection diodes must be used, following the above diagram.

Board diagram

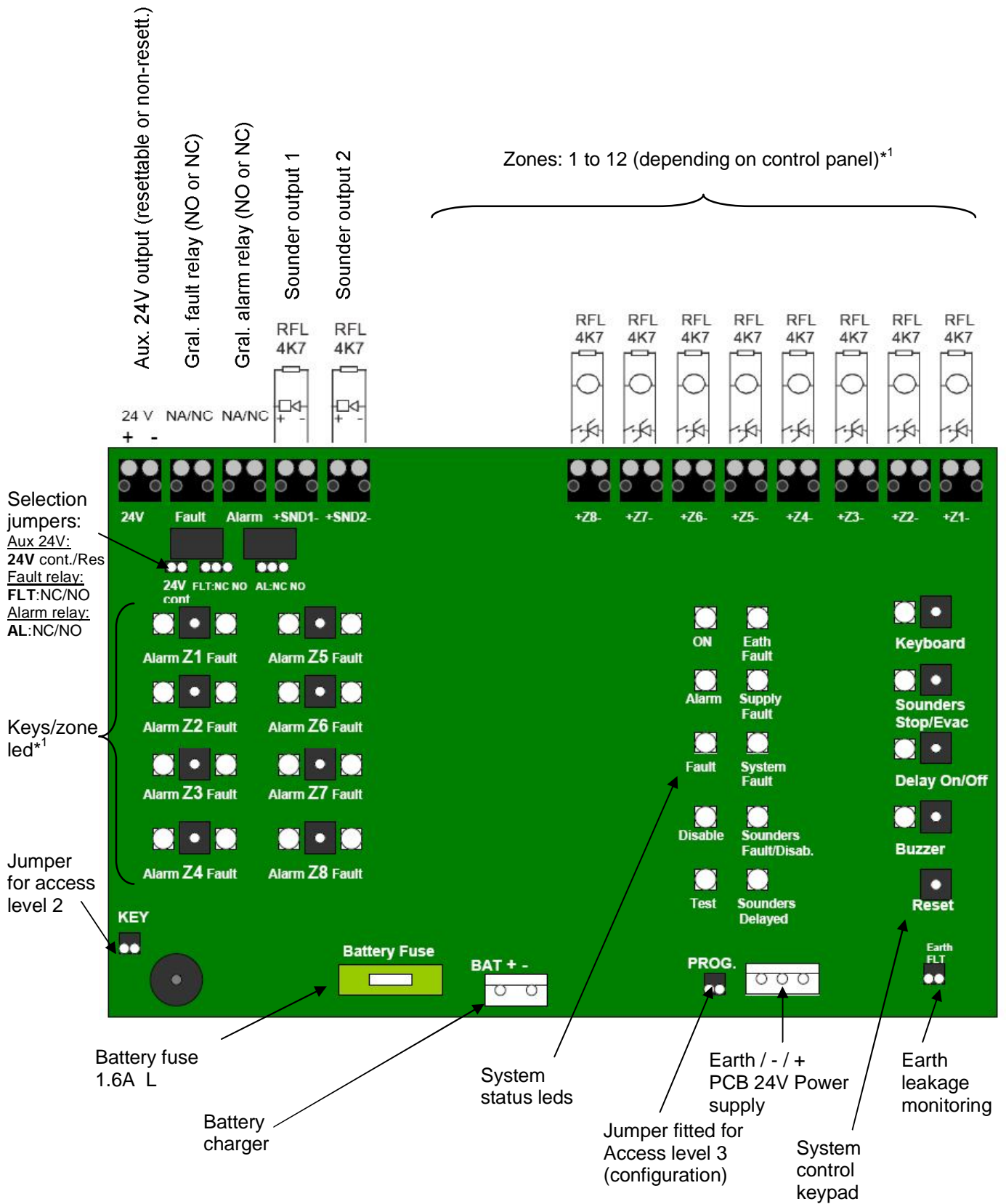

*1 This diagram is a FL8-LT-XP control panel board.

CONFIGURATION

Introduction

Access level 3 allows input, output and control functions to be configured.

Before changing the panel configuration, read this section carefully. Do not make any changes in the configuration unless you have completely understood the operation of the panel.

The default configuration is valid for most installations and does not need to be modified.

Please observe that some configurable functions available may contravene local applicable regulations.

Level 3 access (configuration)

Inside level 3, the system leds and push-buttons have special functions. Check each option to know its meaning and usage.

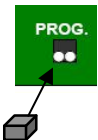

Configuration access (PROG)

In order to enter the configuration menu, connect the supplied jumper between the PROG connector pins on the main board. **The buzzer will sound briefly every 10 seconds to indicate the access to level 3. The fault relay will remain activated while the panel is in level 3.**

Exit configuration

Once the configuration is finished, remove the jumper from the PROG connector on the main board and the configuration will be save in the inner memory.

Default configuration

FLx-LT-XP is supplied with the following configuration, suitable for most installations. Refer to configuration options for further information:

- Sounders **without delays** (Delay 1= Delay 2 = 0s).
- **Zone type = Normal (all): Immediate activation of zone alarm.**
- **Zone short circuit = Fault.**
- **All zones activate all sounders. Detectors perform delays and call points not.**
- **Disablement led on with delays.**
- **2 Zones in alarm do not cancel delays.**
- **Latching faults.**

To restore the default configuration of the control panel:

- i) Fit the configuration jumper (Level 3).
- ii) Keep the Keypad Access push-button pressed while you are entering the access code (1221) by pressing the zone keys in this order: Z1, Z2, Z2 and Z1. Control panel quits the configuration mode and the buzzer activates with a quick intermittent sound.
- iii) Remove the configuration jumper. The default configuration is saved.

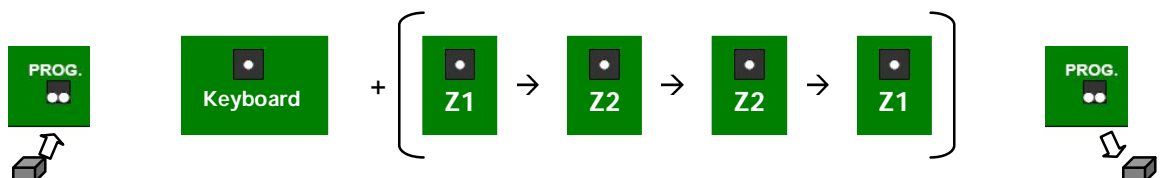

Special configuration options:

- **Latching faults, mains supply and batteries monitoring.**
- **Zone alarm for normal consumption.**

DELAY 1 (alarm acknowledge)

Delay 1: Maximum time to press Buzzer Mute key in order to acknowledge (accept) the alarm and start Delay 2. If the Buzzer Mute key is not pressed, sounders will be activated when the delay 1 time is finished. It is possible to configure 0 seconds (only delay 2 is performed) to 300 seconds (5 minutes) in steps of 30 seconds.

Delay 1 configuration (R1):

Select Delay 1 by pressing **Buzzer Mute (ON)** push-button. Then, press **RESET** push-button to change cyclically the led to be on and, consequently, the period of time.

Configured time indication:

- no led ON = 0 sec. only delay 2 (by default)
- Led 1 ON = ON = 30 sec.
- Led 2 Alarm = ON = 60 sec.
- Led 3 Fault = ON = 90 sec.
- Led 4 Disable = ON = 120 sec.
- Led 5 Test = ON = 150 sec.
- Led 6 Earth Fault = ON = 180 sec.
- Led 7 Supply Fault = ON = 210 sec.
- Led 8 System Fault = ON = 240 sec.
- Led 9 Sounders Fault = ON = 270 sec.
- Led 10 Sounders Delayed = ON = 300 sec.

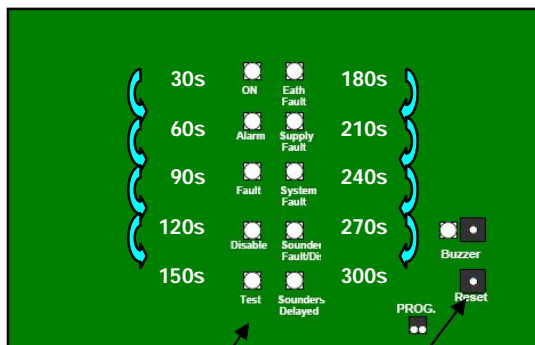

Configured time indication

Press RESET to change the time

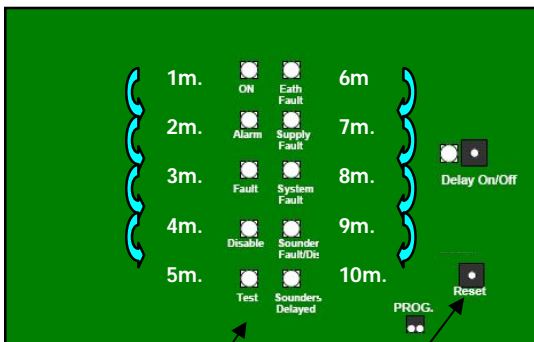

Configured time indication

Press RESET to change the time

DELAY 2 (alarm inspection)

Delay 2: Period of time available to check the alarm cause after pressing BUZZER MUTE push-button. After this time, sounder outputs will activate. SOUNDERS STOP push-button should be pressed to cancel sounders activation.

It is possible to configure a period of time from 0 sec. (only Delay 1 is performed) to 10 minutes at 1 minute intervals.

Delay 2 configuration (R2):

Select Delay 2 by pressing **Delay On/Off = ON** push-button. Then, press **RESET** push-button to change cyclically the led to be on and, consequently, the period of time.

Configured time indication:

- no led ON = 0 sec. only delay 2 (by default)
- Led 1 ON = ON = 1 min.
- Led 2 Alarm = ON = 2 min.
- Led 3 Fault = ON = 3 min.
- Led 4 Disable = ON = 4 min.
- Led 5 Test = ON = 5 min.
- Led 6 Earth Fault = ON = 6 min.
- Led 7 Supply Fault = ON = 7 min.
- Led 8 System Fault = ON = 8 min.
- Led 9 Sounders Fault = ON = 9 min.
- Led 10 Sounders Delayed = ON = 10 min.

DELAYED OPERATION:

Total delay time, delay 1 + delay 2, is 10 minutes (EN54-2). The delay is indicated by means of *Sounders Delayed* and *Disabling* leds ON at the control panel.

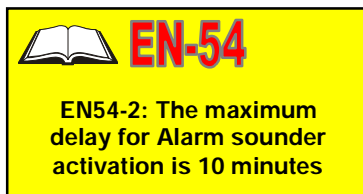

NOTE: The sounders output operation depends on the zone configuration. Refer "Sounder activation by zone" paragraph for more information.

Zone yellow led:
Short circuit = fault



Zone red led:
Short circuit = alarm



Press the zone key to change its operation

Fault / Alarm by short circuit

FLx-LT-XP can be configured so that a zone short circuit produces a short circuit fault (EN54) or a fire alarm.

Zone short circuit configuration: fault/alarm:

Select a zone by pressing the relevant Zone key **ZONE =ON (yellow or read)**. The zone led will be lit in red or yellow, depending on the short circuit configuration in zone (fault or alarm).

Press the **Zone** key to change the short circuit options in zone.

Led 1 ON = **Fault (by default)**. A short circuit in the zone lines is indicated as a fault (EN54-2).
indicated as a call point alarm.

Zone type

Zone type: Each alarm zone operation can be configured to define how the alarm condition is reached.

Zone type configuration:

Select a zone by pressing the relevant Zone key **ZONE =ON (yellow or read)**. The zone led will be lit in red or yellow, depending on the short circuit configuration in zone (fault or alarm).

Press the **Reset** key to change the short circuit options in zone.

- **Led 1 ON Normal (by default)**. Zone alarms are activated immediately.

- **Led 2 Alarm Delay contact (470 ohms)**. To be used with flaw switches or contacts with 470Ω alarm resistor which require that the alarm condition remains for 30 seconds before the control panel indicates an alarm. Call points activate the alarm immediately.

- **Led 3 Fault Checking**. This option requires a second acknowledge (confirmation) within 10 minutes or the activation of the same or any other zone. The zone is reset with the first alarm and is confirmed if there is any other alarm in 10 minutes. After 10 minutes, the process will start again.

- **Led 4 Disablement Delay contact (470 ohms) and Zener**. Both alarm contacts with 470Ω alarm resistor and call points must keep the alarm condition for 30 seconds, otherwise the alarm will not be indicated.

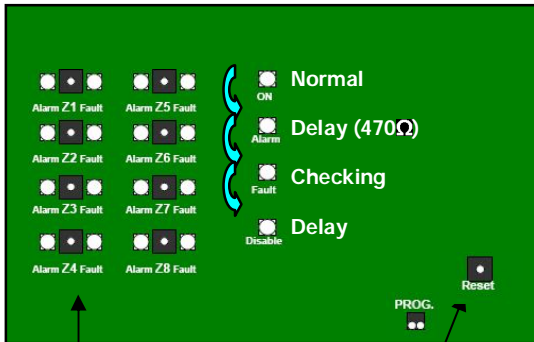

Press the zone key to be configured



Press Reset to change type

Sounder activation by zone

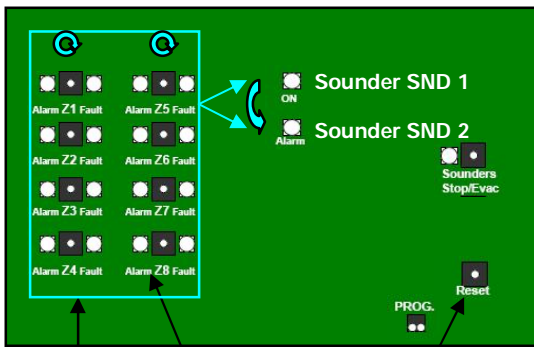

Zone led:
sounder
activation
mode by zone

Press Reset to
select Sounder
1 or 2

Press the zone key
to change the
sounder activation
mode.

Sounders activation in zones can be configured independently for detectors and call points: delays operation (delay 1 and 2) and whether the zone activates or not the sounder.

Sounder activation by zone:

Select sounder configuration menu by pressing the **SOUNDERS STOP/EVAC** push-button.

Change the selected sounder by pressing **Reset**:

- Led 1 ON = Sounder SND 1
- Led 2 Alarm = Sounder SND 2

For the selected sounder:

Press the **ZONE** key to select the sounder activation mode for each zone, according to this table:

Red	Yellow	Activation mode by zone
off ●	on ●	Detectors with delay / MCP without delay
on ●	off ●	Detectors and MCP with delay
on ●	on ●	Detectors and MCP without delay
off ●	off ●	Sounder is not activated

All zones activate all sounders by default, allowing delays 1 and 2 for detectors (yellow led only) and MCP without delay.

Note: To exit this option, press **SOUNDERS STOP/EVAC** push-button again. The control panel will return to configuration 1 option (delay 1)

Disablement led indication with delay

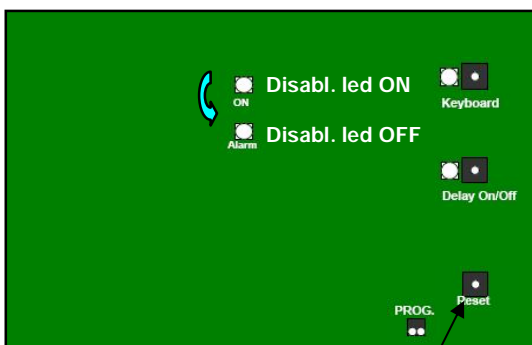

Press Reset to
change
Disablement with
delays

By default, the disablement led is lit when a delay is activated. The control panel can be configured so that the delay turns on the Disablement led (EN54-2) or only the Sounders Delayed led.

Configuration of disablement led with delays:

Select the sounders configuration menu by pressing at the same time the following keys: **KEYBOARD=ON + DELAY ON/OFF=ON**.

Cyclical change of disablement led option with **RESET** key:

- Led 1 ON = **Disablement led ON with delays (by default) (EN54-2)**
- Led 2 Alarm = **Disablement led OFF with delays (only Sounders Delayed led)**

Cancel delays with 2 zones in alarm

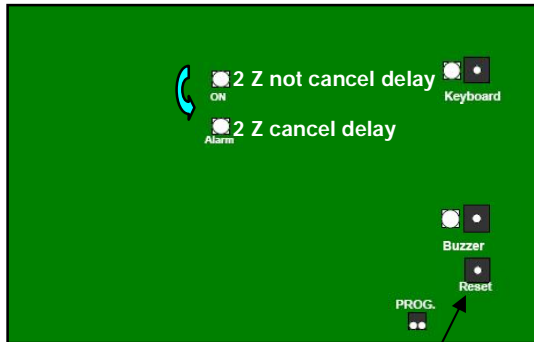

Press Reset to change disablement with delays

In case of zone alarm with delays, the zones in alarm can be configured to cancel delays.

Configure: 2 Zones cancel delays

Select the configuration menu of cancel delays with zones in alarm by pressing at the same time the following keys: **KEYBOARD=ON + BUZZER=ON**

Cyclical change of Disablement led option with **RESET**

Led 1 ON	= No (by default)
Led 2 Alarm	= Yes. When there are two zones in alarm, the sounders activate immediately even though there are delays already configured or operating.

SPECIAL FUNCTIONS (DO NOT COMPLY WITH EN54)

Special configuration for installations which do not require EN54 compliance

The FLx-LT-XP control panel allows special configurations for resettable faults, operating at 24V in navy applications or at 220Vca as a dependent system. These configurations do not comply with EN54-2/4 and can only be used for special performances.

The manufacturer recommends not to use these special configurations because the system will not operate properly and will not comply with EN54-2/4 standard.

Only with the consent of the competent authorities, the user may use these special configurations for navy and automotive industry or integrated subsystems.

Special functions configuration:

To configure special functions, switch off the control panel (mains supply and batteries disconnection), then connect the jumper at PROG switch and connect again the control panel as usual. Special functions leds will be lit, according to their configuration:

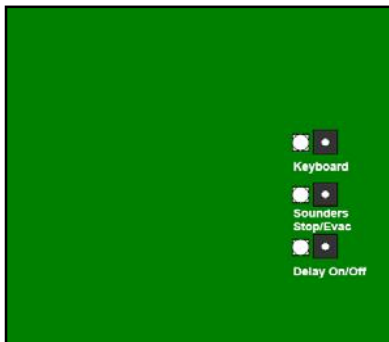

KEYBOARD led	=ON= Latched faults. Faults need to be RESET (by default) =OFF=Resettable faults. Faults RESET automatically when the fault has disappeared.
SOUNDERS led	=ON= 220V power supply fault are indicated (by default) =OFF= 220V power supply faults are not indicated.
DELAY ON/OFF led	=ON = Battery faults are indicated (by default) =OFF= Battery faults are not indicated.

FLx-LT-XP special functions configuration (by default)

When the FLx-LT-XP control panel is operating with the special functions configuration (PROG jumper fitted), the three leds above are ON.

To change the special functions configuration, press the push-button you want to change, Keyboard, Sounders Stop or Delay on/off, according to the above settings.

Remove the PROG jumper and the control panel will save the configuration and show the current status of the system.

TECHNICAL SPECIFICATIONS

General

FLx-LT-XP control panels (FL2/4/8/12-LT-XP) have been designed to comply with EN 54, part 2/4 requirements.

This control panel complies with the European Low Voltage Directive 73/23/EEC (and the amending Directive 93/68/EEC), by the application of the safety standard EN 60950.

The panel conforms to the essential protection requirements of the EMC Directive 89/336/EEC (and the amending Directives 92/31/EEC and 93/68/EEC) by the application of EN 50081-1, (emissions) and EN 50130-4, (immunity).

Mechanical:

Construction:	ABS plastic cover and back box. Colour: RAL9002
Dimensions (mm):	315 (h) x 380 (w) x 100 (d)
Approx. weight:	3 kg (no batteries)

Environmental:

Operating temperature:	5 to 35°C (-5 to 45°C max.)
Humidity:	5 to 95% R.H. (non-condensed)
Height above sea level:	Maximum, 2000 m
Panel sealing:	IP 30, (EN 60529)
Vibration:	EN 60068-2-6, 10-150 Hz at 0,981ms ⁻² , 0,1g _n (Meets the requirements of EN 54-2/4)
EMC	Emissions: EN 50081-1 Immunity: EN 50130-4
Safety:	EN 60950

Fuses:

Mains supply:	F 4A L 250V
Sounders:	Resettable fuse; 250mA independent by sounder
Aux. 24V	Resettable fuse; 300mA max. (FL2/4-LT-XP); 600 mA max. (FL8/12-LT-XP)
Battery:	F 1.6A L 250V

LED indicators:

LED status indicators: *1: ALARM, Zone alarm and fault, general fault, general disablement, test, earth fault, power supply fault, system fault, sounder fault/disabled, delayed sounders and 2 status leds by zone.

LED indicators in keys *1: Access level 2, Sounders Stop, Delay On/off, Buzzer Mute and zone disabled or in test.

*1 In Access level 3, the FLx-LT-XP leds have special indication functions.

Controls:

Pushbuttons are provided for the following functions *2:

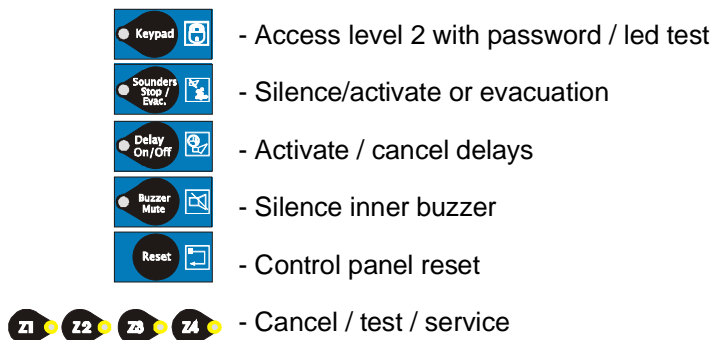

*2 In Access level 3, the push-buttons have selection functions.

Earth leakage monitoring jumper (EARTH FAULT)

Level 3 access jumper (PROG)

Supply rating:

Mains supply to the panel is to be provided via an external double-pole mains isolation unit. The supply rating is:

90-264V~ (ac), 50/ 60Hz, 45W (1.6A.) for VNS2/4 LT:

90-264V~ (ac), 50/ 60Hz, 65W (2.4A.) for VNS8/12 LT:

Power supply specification:

Input fuse rating: T 4A L 250V (5 x 20 mm)

Output ratings:

Output voltage: 27Vdc +/-7%

Output current: VNS2/4 LT: 1.6A (max. external circuits load 1.2A: zone circuits, sounders and Aux 24V)

VNS8/12 LT: 2.4A (max. external circuits load 1.8A: zone circuits, sounders and Aux 24V)

Output ratings - Charger:

Charger voltage: 27.3V at 20°C (compensated temperature)

Charging current: 260mA

Battery 80% charged in 24 hours: 7Ah

EMC: EN55022 Class B;
EN61000/2/3; EN61000/4/2,3,4,5,6,8,11; ENV50204

Safety: UL60950

Recommended battery size:

12V 7Ah sealed, lead-acid battery.

Note 2: Batteries must be replaced every four years at the latest. Battery life span depends on the environmental temperature. Refer to the manufacturer specifications.

External circuits *1:

Zone circuits

FLx-LT-XP can be supplied with two (FL2-LT-XP), four (FL4-LT-XP), eight (FL8-LT-XP) or twelve (FL12-LT-XP) detector and/or call points zone circuits. FLx-LT-XP control panel is designed to be compatible with most brands. ECO1000 detectors are recommended.

FLx-LT-XP control panel supports 32 ECO1000 detectors per zone and an unlimited number of call points.

Max. voltage in zone 27.5Vdc (Normal) at 21Vdc.

Status zone values are indicated in approximate % with regard to the normal max. zone voltage (27.5 Vdc).

Short circuit fault*1	0% - 7% de 27.5V (< 1.9Vdc / > 54mA)
Call point alarm:	7% - 27% de 27.5V (range:1.9Vdc/54mA at 7.4Vdc/42mA)
Detector alarm:	27% - 70% de 27.5V (range:7.4Vdc/42mA at 19Vdc/17mA)
Standby:	70% - 93% de 27.5V (range:19Vdc/17mA at 25.5Vdc/4mA)
Open circuit:	93% - 100% de 27.5V (> 25,6Vdc)

*1 Maximum current in zone: 57mA at 0V

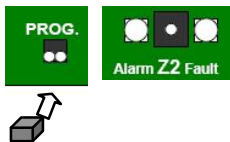

*2 Special function for alarm with low power detectors (27% - 87%). To select alarm for low power detectors, such as **ESSER 9000 Series**, switch off the control panel and connect again with the PROG jumper fitted. Press Z2 push-button to select the right option which will be indicated through the Z2 yellow led:

Normal zone: Zone 2 yellow led = OFF

ESSER Zone: Zone 2 yellow led = ON

Remove the PROG jumper. The control panel will save the configuration and show the current status of the system.

2 Sounder circuits:

FLx-LT-XP provides two monitored and configurable outputs.

Maximum load: 0.250A in alarm, with resettable electronic protection.

2 Relays (alarm and fault):

Contacts: NC or NO configurable by jumper, maximum 30Vdc/ 1A (resistive load).

Aux. 24V output:

FLx-LT-XP control panel provides Aux 24V: 24V continuous or 24V resettable, configurable by jumper.

18.5 – 28.5Vdc (24Vdc nominal) / 0.3A max. (FL2/4-LT-XP) and 0.6A max. (FL8/12-LT-XP)

Notes:



FIRE·LITE[®] ALARMS
by Honeywell